



190252 (GFC-501) 20 OZ. ACETAL GRAVITY FEED CUP

Important: Before using this equipment, read all safety precautions and instructions. Keep for future use.

Note

This cup is compatible for use with Halogenated Hydrocarbon solvents such as 1, 1, 1 Trichloroethane and Methylene chloride.

DESCRIPTION

GFC-501 (acetal) 20 Oz. Cup

This gravity feed cup is designed to work with the GFG, GFHV, GTI and FLG gravity feed spray guns and with or without the DeVilbiss disposable cup liner. The cup liner allows painting in any position and simplifies clean up. The cup is constructed from acetal which is easier to clean and resists stains better than nylon. This cup has a unique drip check lid to prevent paint from dripping out of the vent in the lid. It has a high grade stainless steel connector, compatible with waterbornes and all common coating materials.

INSTALLATION

Protective coatings have been used to protect the cup after manufacture. Flush all equipment with a suitable solvent before use to remove these coatings from the material passages.

ASSEMBLY OF CUP TO GUN

1. Remove the cup gasket (3) from the poly bag.
2. Place this cup gasket in the fluid inlet of the gun body. See Cup Drawings.
3. Store remaining cup gasket in a safe place for future use.
4. Place filter (4) in cup outlet at this time if desired. See Cup Drawings.
5. Assemble cup to gun and tighten hand tight.

FILLING WITH PAINT

Fill the cup with paint to the bottom of the threads. **Do not overfill.**

INSTALLING THE LID

Place plastic lid on the top of the cup, and **hand tighten**. Fold vent cap and push onto center portion of lid (if vent cap is not already assembled).

PAINTING

This disposable liner allows you to spray in any position, even upside down. To spray upside down, you must first purge the air from the cup liner.

To purge air from cup liner:

1. Connect to proper air supply (minimum of 30 PSI)
2. Turn cup upside down (See Figure below)
3. Trigger gun until a constant paint flow is observed.

CLEANING

Note

For routine cleaning, it is not necessary to remove cup from gun. Do not remove washer (3) from gun. If washer (3) is removed, it must be replaced.

Remove lid and properly dispose of any excess paint. Pour in a small amount of clean solvent. The amount will vary with different coatings and solvents. Reinstall lid. Shake cup to wash down the inside surfaces. Pull trigger to allow some solvent to be flushed through gun. Remove lid and pour out dirty solvent. Add a small amount of clean solvent and repeat procedure. Wipe exterior of cup and lid with a clean cloth and clean solvent.

If a paint filter was used in the bottom of the cup outlet, it should be removed and cleaned or replaced at this time.

CUP DRAWINGS

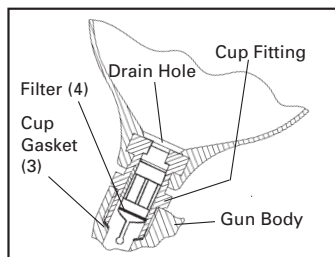

PARTS LIST

Ref. No.	Replacement Part No.	Description
1	GFC-501	Cup Assembly, 20 oz. Acetal
2	GFC-402	Cup Lid Assembly
3	KGP-13-K5	Cup Gasket (Blue) (Kit of 5)
4	KGP-5-K5	Filter (Kit of 5)

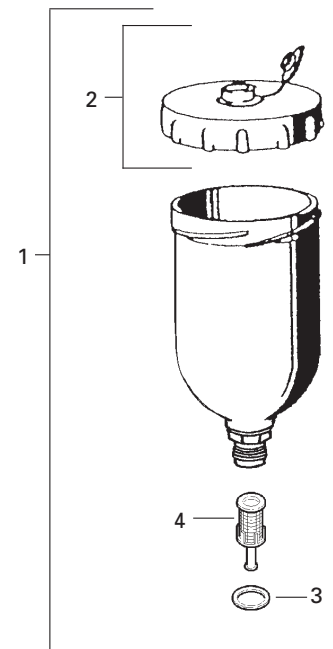

ACCESSORIES

OMX-70-K48 PAINT CUP LINER KIT (Not for use with GFC-503 cups)

Allows quick and easy clean-up.

Consists of :

- 1 - Piercing Tool
- 48 - Disposable Liners
- 48 - Drain Bushings

IMPORTANT! DO NOT DESTROY

It is the Customer's responsibility to have all operators and service personnel read and understand this manual. Contact your local DeVilbiss representative for additional copies of this manual.

READ ALL INSTRUCTIONS BEFORE OPERATING THIS DEVILBISS PRODUCT.

WARRANTY POLICY

This product is covered by Carlisle Fluid Technologies' materials and workmanship limited warranty. The use of any parts or accessories, from a source other than Carlisle Fluid Technologies, will void all warranties. Failure to reasonably follow any maintenance guidance provided may invalidate any warranty.

For specific warranty information please contact Carlisle Fluid Technologies.

For technical assistance or to locate an authorized distributor, contact one of our international sales and customer support locations.

Region	Industrial / Automotive	Automotive Refinishing
Americas	Tel: 1-800-992-4657 Fax: 1-888-246-5732	Tel: 1-800-445-3988 Fax: 1-800-445-6643
Europe, Africa, Middle East, India	Tel: +44 (0)1202 571 111 Fax: +44 (0)1202 573 488	
China	Tel: +8621-3373 0108 Fax: +8621-3373 0308	
Japan	Tel: +81 45 785 6421 Fax: +81 45 785 6517	
Australia	Tel: +61 (0) 2 8525 7555 Fax: +61 (0) 2 8525 7575	

For the latest information about our products, visit www.carlisleleft.com

Carlisle Fluid Technologies is a global leader in innovative finishing technologies. Carlisle Fluid Technologies reserves the right to modify equipment specifications without prior notice.

BGK™, Binks®, DeVilbiss®, Hosco®, MS®, and Ransburg® are all registered trademarks of Carlisle Fluid Technologies, Inc.

©2020 Carlisle Fluid Technologies, Inc.
All rights reserved.

