

Spray Gun Lubrication

Daily, apply a drop of SSL-10 spray gun lube at trigger bearing stud (11) and the stem of the air valve (9). The shank of the fluid needle (8) where it enters the packing nut (8) should also be oiled. The fluid needle packing (8) should be kept soft and pliable by periodic lubrication. Make sure the baffle (5) and retaining ring (1) threads are clean and free of foreign matter. Before assembling retaining ring to baffle, clean the threads

screw (7) to relieve spring pressure against needle collar.

Chart 1 – Air Caps

Air Cap (Ref. No. 2)		Application
Part No.	Computer No.	
FLG-1-1	690000	Conventional
FLG-1-3	690001	HVLP

Chart 2 – Fluid Tips

Fluid Tip (Ref. No. 3)		Fluid Tip Size (in.)	Fluid Tip Size (mm)	Applications
Part No.	Computer No.			
FLG-332-13K	803051	0.051	1.3	Stains, lacquers, basecoats, clears.
FLG-332-15K	803052	0.059	1.5	General purpose, light to medium viscosity material.
FLG-332-18K	803053	0.070	1.8	Primers and medium viscosity materials.
FLG-332-22K	803054	0.086	2.2	Latex and heavy materials.

Chart 3 – HVLP Air Flows (#3 Cap)

Inlet Press. (PSI)	Air Flow (SCFM)	Cap Press. (PSI)
15	10	6
19	11.5	8
23	13	10

Gun Drawing

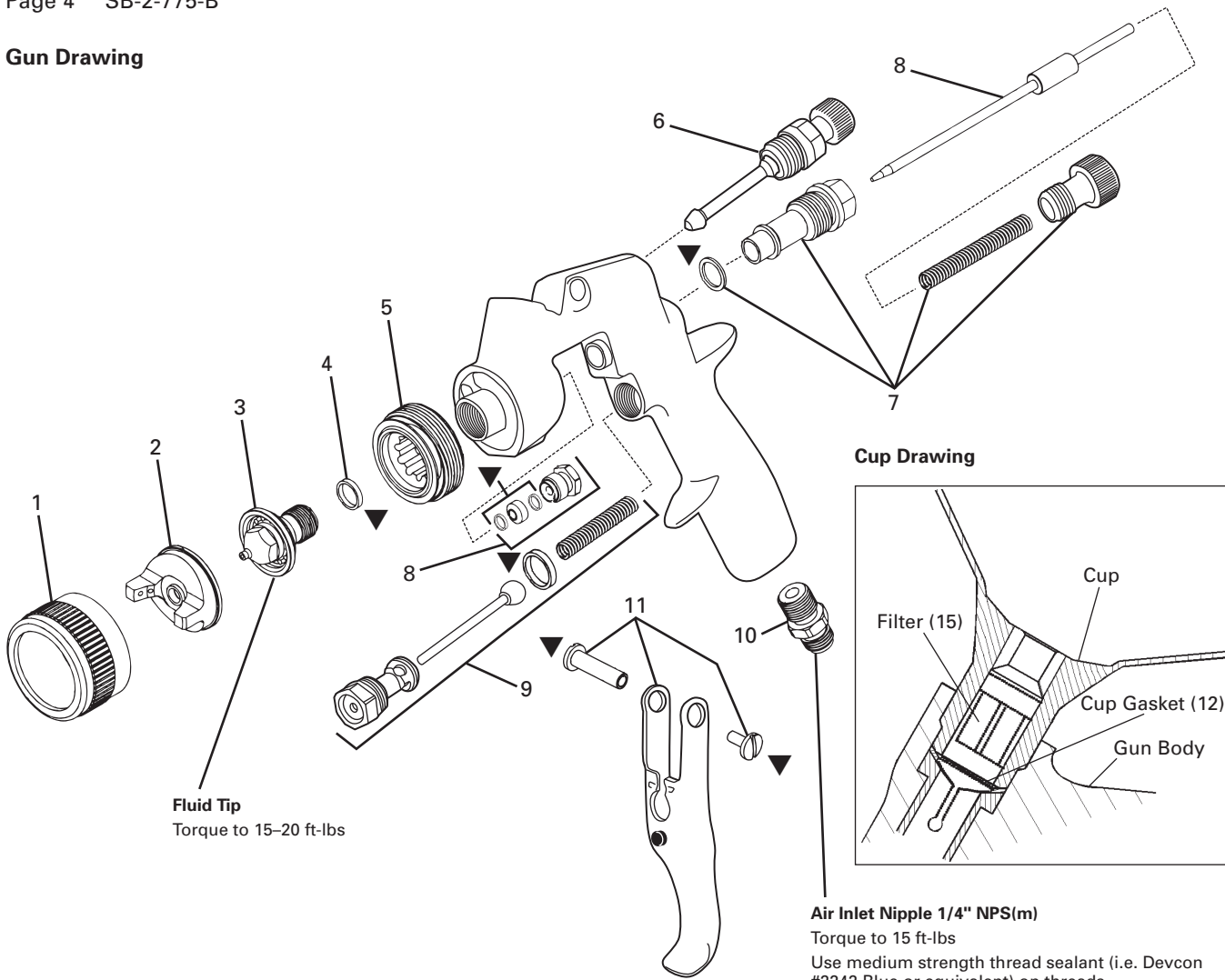

Fluid Tip
Torque to 15-20 ft-lbs

Cup Drawing

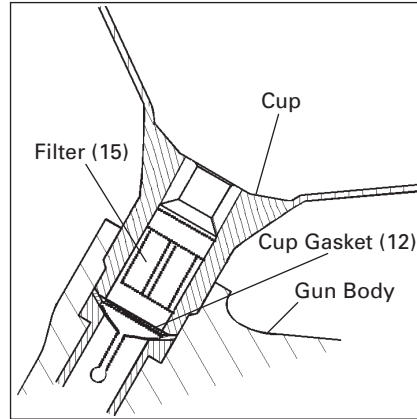

Air Inlet Nipple 1/4" NPS(m)
Torque to 15 ft-lbs
Use medium strength thread sealant (i.e. Devcon #2242 Blue or equivalent) on threads

PARTS LIST

Ref. No.	Comp. Part No.	Replacement Part No.	Description	Ind. Parts Req.
1	803055	FLG-333	Retaining Ring	1
2		See Chart 1	Air Cap	1
3		See Chart 2	Fluid Tip & Seal Kit	1
4	690020	FLG-304-K5	Fluid Tip Seal (Kit of 5)	1
5	690021	FLG-305	Baffle	1
6	803528	FLG-465	Spreader Air Adjustment Valve	1
7	803525	FLG4-364-K	Needle Knob, Spring, Bushing & Gasket Kit	1
8	803526	FLG4-366-K	FLG4 Needle, Needle Packing & Nut Kit	1
9	190780	JGS-449-1	Air Valve & Gasket Kit	1
10	190287	P-MB-51	Air Inlet Nipple	1
11	191943	JGS-477-1	Trigger, Trigger Stud & Screw	1
12	192151	KGP-13-K5	Cup Gasket Kit (Kit of 5)	1
13	702576	702576	Metal Gravity Feed Cup	1
	190252	GFC-501	Acetal Gravity Feed Cup	1
14	190944	GFC-404-K2	Disposable Lid Kit (Kit of 2)	1
15	190181	KGP-5-K5	Filter Kit (Kit of 5)	1

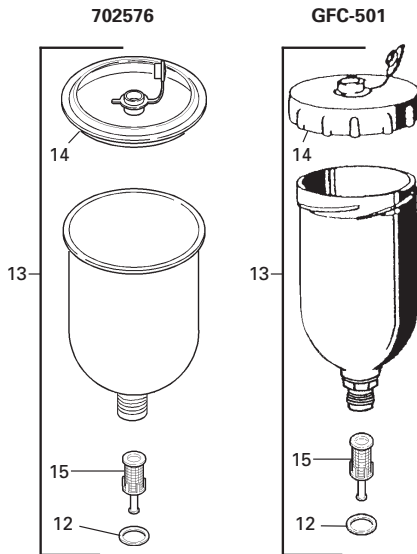

803527 FLG4-488-K ▼ FLG4 Gun Repair Kit (Contains 1 each: Fluid Tip Seal, Needle Packing, Trigger Stud, Trigger Screw, and Gasket for Air Valve & Needle Bushing.)

519210 FLG-463 Air Cap #3 HVLP Test Cap

Additional Spray Gun Accessories on page 7.