



Parts Replacement/Maintenance

Chart 1 – Air Cap

ORDER NO. FOR AIR CAP	NUMBER ON CAP	RECOMMENDED INLET PRESSURE BAR/PSI	AIR FLOW LPM/SCFM
703899 (HVLP)	HV20	1.0 – 1.3 bar 14 – 18 psi	317 – 368 LPM 11.2 – 13.0 SCFM

NOTE 1: Guns with HVLP caps must not exceed 0.7 bar (10 psi) air cap pressure with gun fully triggered. (Approximately 24 psi gun inlet pressure.) (See accessories for air cap test kit which is available to set the exact cap pressure.)

NOTE 2: When removing air cap from retaining ring, don't remove slip ring (2) or retaining ring seal (5) from retaining ring. Damage to the parts may occur. Slip ring and retaining ring seal are not available as replacements. Simply wipe parts clean and reassemble with new or clean air cap.

Chart 2 – Fluid Nozzles & Fluid Needles

NO. ON FLUID NOZZLE	TIP SIZE I.D. (MM)	NO. ON FLUID NEEDLE (TO MATCH FLUID NOZZLE)	ORDER NO. FOR NOZZLE & NEEDLE SET
SN-37-11	1.1	SN-38-11	702711
SN-37-12	1.2	SN-38-12	702712
SN-37-13	1.3	SN-38-13	702713
SN-37-14	1.4	SN-38-14	702714
SN-37-15	1.5	SN-38-15	702715

NOTE: When replacing the fluid nozzle or fluid needle, replace both at the same time. Lightly lubricate the threads of the fluid nozzle before reassembling. Torque to 18–20 Nm (13–15 ft-lbs). Don't over tighten the fluid nozzle. Use 10 mm wrench supplied with gun.

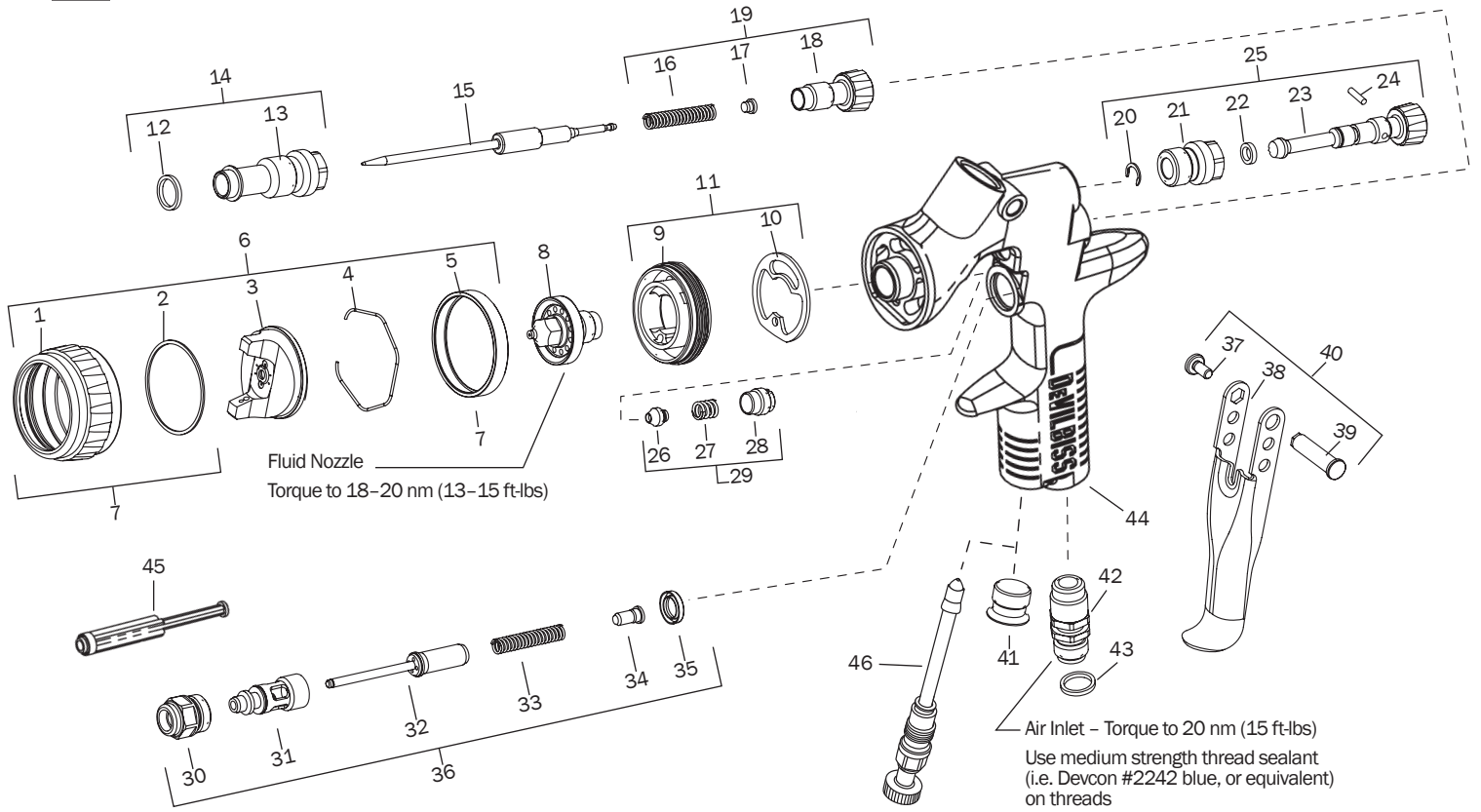

REF. NO.	DESCRIPTION	PART NO.	QTY
1	Air Cap Retaining Ring		1
2	Slip Ring		1
3	Air Cap		1
4	Air Cap Retaining Clip	191972	1
5	Retaining Ring Seal		1
6	Air Cap & Ring	See Chart 1, p.11	1
7	Air Cap Retaining Ring & Seals	703896	1
8	Fluid Nozzle	See Chart 2, p.11	1
9	Air Separator		1
*10	Air Separator Seal (kit of 2)	702726	1
11	Air Separator & Seal Kit	703900	1
*12	Body Bushing Gasket		1
13	Body Bushing		1
14	Body Bushing & Gasket	702728	1
15	Fluid Needle	See Chart 2, p.11	1
*16	Needle Spring		1
*17	Needle Spring Pad		1
18	Fluid Adjusting Knob		1
19	Fluid Adjusting Knob, Spring, & Pad Kit	703897	1
*20	Retaining Clip		1
21	Spreader Valve Body		1
*22	O-ring		1
23	Spreader Valve Adjusting Knob		1
*24	Spreader Valve Pin		1
25	Spreader Valve Assembly	703898	1

REF. NO.	DESCRIPTION	PART NO.	QTY
*26	Needle Packing		1
*27	Packing Spring		1
*28	Packing Nut		1
29	Packing, Spring & Packing Nut Kit	702731	1
30	Air Valve Body		1
31	Air Valve Cage		1
32	Air Valve Poppet		1
33	Air Valve Spring		1
34	Air Valve Spring Pad		1
35	Air Valve Seal		1
36	Air Valve Assembly	702732	1
*37	Trigger Stud Screw (T20 Star)		1
38	Trigger		1
*39	Trigger Stud		1
40	Trigger, Stud & Screw Kit	702733	1
41	Plug		1
42	Air Inlet	702734	1
43	Colour ID Ring Kit (4 Colours)	702735	1
44	Gun Body		1
45	Air Valve Service Tool (only included with Air Valve Assembly 36)		
46	Air Adjusting Valve (optional)	702737	1
OTHER SALABLE PARTS / ACCESSORIES			
	Wrench (10 & 14mm)	702740	
	Seal and Pin Kit (Kit of 5) (Items 20, 22 and 24.)	192229	

* The TEKNA Spray Gun Repair Kit (702736) contains all the parts indicated with an asterisk.