

Parts Replacement/Maintenance

Chart 1 – Air Caps

ORDER NO. FOR AIR CAP	NUMBER ON CAP	RECOMMENDED INLET PRESSURE BAR/PSI	AIR FLOW LPM/SCFM
704165 (High Efficiency)	PR10	1.8 – 2.0 bar 26 – 29 psi	311 – 340 LPM 11 – 12 SCFM
704166 (HVLP)	PR30	1.2 – 1.4 bar 17 – 21 psi	396 – 453 LPM 14 – 16 SCFM

NOTE 1: Guns with HVLP caps must not exceed 0.7 bar (10 psi) air cap pressure with gun fully triggered. (Approximately 21 psi gun inlet pressure.) (See accessories for air cap test kit which is available to set the exact cap pressure.)

NOTE 2: When removing air cap from retaining ring, don't remove slip ring (2) or retaining ring seal (5) from retaining ring. Damage to the parts may occur. Slip ring and retaining ring seal are not available as replacements. Simply wipe parts clean and reassemble with new or clean air cap.

Chart 2 – Fluid Nozzles & Fluid Needles

ORDER NO. FOR FLUID NOZZLE	NO. ON FLUID NOZZLE	TIP SIZE I.D. (MM)	NO. ON FLUID NEEDLE	ORDER NO. FOR FLUID NEEDLE
704168	PRIPRO-220-14	1.4	PRIPRO-320	704167
704169	PRIPRO-220-16	1.6		
704170	PRIPRO-220-18	1.8		
704171	PRIPRO-220-20	2.0		
704172	PRIPRO-220-25	2.5		

NOTE: When replacing the fluid nozzle or fluid needle, replace both at the same time. Lightly lubricate the threads of the fluid nozzle before reassembling. Torque to 18–20 Nm (13–15 ft-lbs). Don't over tighten the fluid nozzle. Use 10 mm wrench supplied with gun.

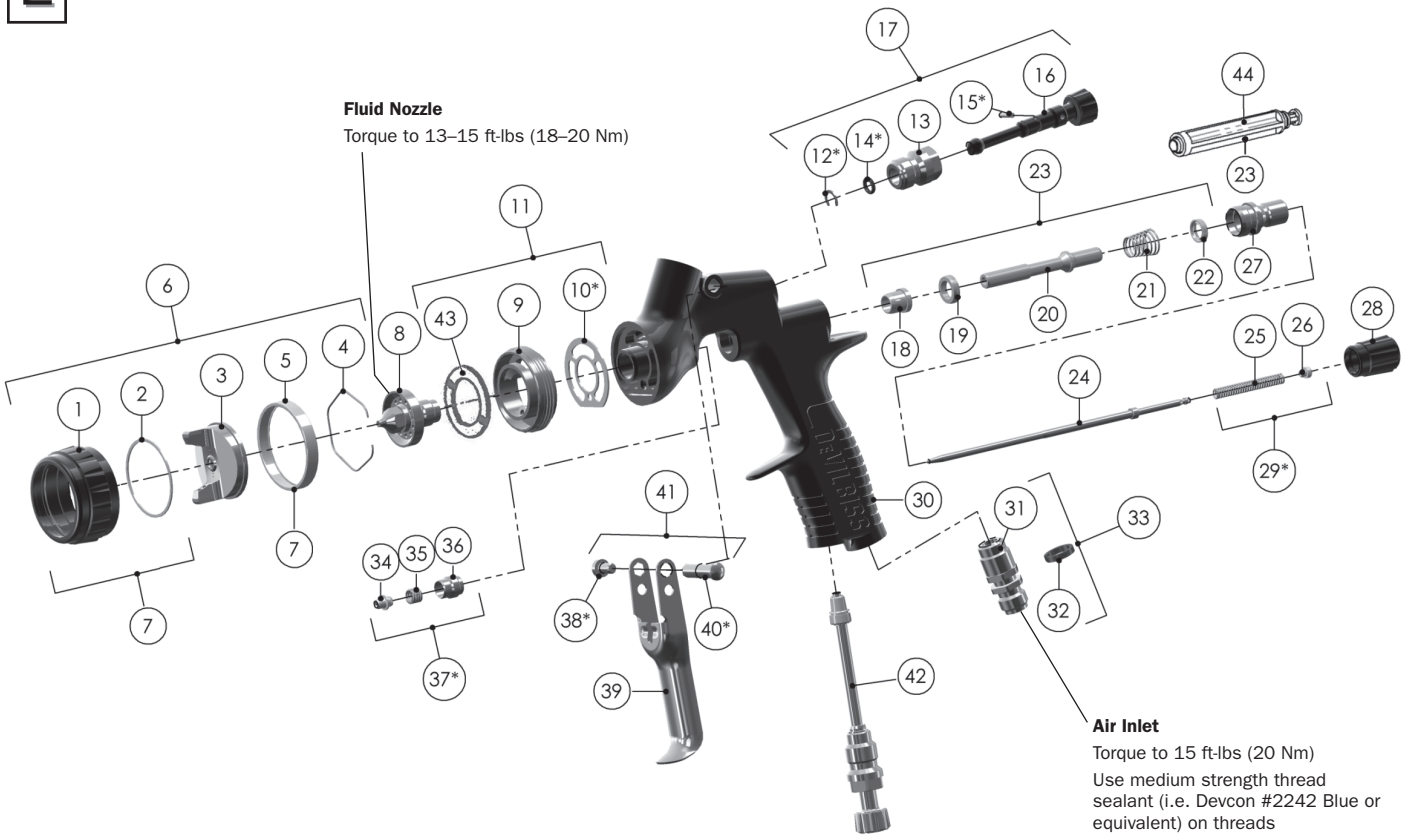

REF. NO.	DESCRIPTION	PART NO.	QTY
1	Air Cap Retaining Ring		1
2	Slip Ring		1
3	Air Cap		1
4	Air Cap Retaining Clip	191972	1
5	Retaining Ring Seal		1
6	Aircap & Ring	See chart 1 p11	1
7	Air Cap Retaining Ring & Seals	703896	1
8	Fluid Nozzle	See chart 2 p11	1
9	Spray head		1
*10	Spray head Seal	702726	1
11	Spray head kit	703529	1
*12	Circlip		1
13	Valve Body		1
*14	O Ring		1
*15	Spreader Valve Pin		1
16	Spreader Valve Adjusting Knob		1
17	Spreader Valve Assembly	703898	1
18	Front Valve Seal		1
19	Valve Seat		1
20	Spindle		1
21	Air Valve Spring		1
22	Rear Valve Seal		1
23	Air Valve Kit	703530	1
24	Fluid Needle	See chart 2 p11	1
25	Needle Spring		1
26	Spring Pad		1
27	Housing & Seal Kit	703532	1
28	Fluid Adjusting Knob	704163	1
*29	Needle Spring Kit	703534	1
30	Gunbody		1

REF. NO.	DESCRIPTION	PART NO.	QTY
31	Air Inlet		1
32	Colour ID Ring Kit (4 Colours)	702735	1
33	Air Inlet Kit	702734	1
34	Needle Packing		1
35	Packing Spring		1
36	Packing Nut		1
*37	Packing, Spring and Packing Nut Kit	702731	1
*38	Trigger Screw		1
39	Trigger		1
*40	Trigger Stud		1
41	Trigger, Stud & Screw Kit	703535	1
42	Cheater Valve	704164	1
43	Baffle Plate	704162	1
44	Air Valve Service Tool (only included in the Air Valve Kit 23)		
SERVICE PARTS			
Spray Gun repair kit (includes items marked *)		703536	
Seal and Pin Kit, kit of 5 (items 12, 14 and 15)		192229	